

Order Forms

KW Home & Garden Show

Sponsored by



March 23 - 25, 2018

**Kitchener Memorial Auditorium Complex
400 East Avenue (at Borden),
Kitchener, Ontario N2H 1Z6
Tel: (519) 741-2545
Fax: (519) 741-2649**

Show Dates and Hours

Friday, March 23rd	12:00 noon - 7:00 p.m.
Saturday, March 24th	10:00 a.m. - 7:00 p.m.
Sunday, March 25th	10:00 a.m. - 5:00 p.m.

Show Management

Ann Evoy, Show Manager,
(519) 632-5222 Fax: (519) 632-5251
Email: ann@kwhgs.ca

www.kwhgs.ca

SHOW BADGES

All badges & passes are to be picked up during your move-in day registration at the Show Office.

Company name: _____ Booth #: _____

Contact Person: _____ Phone: _____

Please print your staff's names below and then **fax this order form back to (519) 632-5251** or mail it to: Kitchener Memorial Auditorium Complex, 400 East Avenue, Kitchener, Ontario, N2H 1Z6.

1.
2.
3.
4.
5.

DO NOT complete the following unless your have a booth over 100 square feet:
**** PLEASE NOTE: Five additional badges for each extra 100 square foot booth.**

Two Booths:

Three Booths

1.	1.
2.	2.
3.	3.
4.	4.
5.	5.

Four Booths:

Five Booths:

1.	1.
2.	2.
3.	3.
4.	4.
5.	5.

Continued on next page.

Six Booths:

Seven Booths:

1.	1.
2.	2.
3.	3.
4.	4.
5.	5.

Eight Booths:

Nine booths

1.	1.
2.	2.
3.	3.
4.	4.
5.	5.

If you wish to purchase any additional badges or passes, please complete the order form "Additional Badges/Passes" on the next page.

ADDITIONAL BADGES & PASSES

**This form must be completed and returned
no later than March 1st, 2018.**

Each 100 sq.ft. booth will automatically receive 5 Full Show Exhibitor Badges and 5 Complimentary Guest Passes. Any additional passes can be ordered below (see bottom of page for payment information).

Company name: _____ Booth #: _____
 Contact: _____ Phone: _____
 Address: _____
 City: _____ Prov.: _____ Postal Code: _____

Additional Passes

I would like _____ complimentary guest passes at \$5.00 each \$ _____
 _____ Packs of ten (10) complimentary guest passes at \$ 40.00 each \$ _____
TOTAL: \$ _____

Additional Exhibitor Badges:

I would like _____ full show exhibitor badges at \$ 5.00 each = \$ _____

1.
2.
3.
4.
5.

Please include a cheque payable to Ontario Marketing Productions Ltd. or complete the credit card authorization form below. (Taxes included in the prices listed above. (G.S.T. #122016769 RT).

Charge to my: Visa MasterCard Direct Payment **Amount: \$** _____
 Card #: _____ Exp. date: _____
 Card Holder Name: _____ Signature: _____

Fax to: (519) 632-5251 or **Mail to:** 400 East Avenue, Kitchener, Ontario, N2H 1Z6

REQUEST FOR APPROVAL CONTEST / DRAW

I wish to make arrangements at my expense to receive my passes in advance Yes ___ No ___

This request for approval for contest / draw must be completed and submitted to the Show Management before the opening of the show. A copy of the signed and approved form will be returned to you.

Company name: _____ Booth #: _____

Contact person: _____

Phone: _____ Fax: _____

Address: _____

Please list the Contest / Draw Prize(s) you will have at your booth below:

- 1) _____
- 2) _____
- 3) _____
- 4) _____

Number of contest / draw prize winners: _____

I, _____, agree to ensure that the names of the contestants entering our contest / draw will be used only for purpose of soliciting sales of our company's products/services. I understand that there can be no soliciting sales of product or service other than those that we sell, by any representative from our company or third party.

Company contact signature

Show Management signature

Date

Date

**Please note that all names of winners must be given to
Show Management on March 25, 2018**

STANDARD BOOTH DRAPE ORDER FORM

The Show Management provides back drapes free of charge, **ONLY** if your Drape Order Form is returned to us no later than **March 1st, 2018.** The Show Management will also provide you, free of charge, with two 3-foot high side drapes if requested. These side drapes **will not automatically** be placed in your booth. You must fill out the order form attached.

Company name: _____ Booth #: _____

Contact: _____ Phone: _____ Fax: _____

Please check one:

- We will require the standard 8 foot high back drape provided at no charge by Show Management.
- We will require the standard 3 foot high side drapes provided at no charge by Show Management.
- We will **not** require the standard booth drape or side drape. We have our own display booth.

Remember there is no charge for the standard booth drape if requested before the deadline. You must let us know by completing and returning this form.

Move-In

To facilitate a fast and trouble free move-in, please complete the following information. We will confirm your move-in with you 2 weeks prior to the show, provided we have received your form. Please indicate the preferred day and time your company would like to move-in.

Move-In Hours Available:

- Wednesday, March 21 8 a.m. - 8 p.m.
- Thursday, March 22 8 a.m. - 8 p.m.
- Friday, March 23*** 8 a.m. - 11 a.m. **(Hand carried items only – NO DOLLIES)**

Preferred time for move-in: _____ Your type of vehicle: _____

Do you require a fork lift? _____ YES _____ NO, If yes, approx. how long: _____

Will you be moving out on: Sunday night _____ or Monday day _____

Please fax this form back to: (519) 632-5251

www.kwhgs.ca



95 Baffin Place, Waterloo, ON N2V 2C1
 800-563-4246
 Fax: 519-746-2188
 Website: www.hahnrentals.com
 Email: Info@hahnrentals.com

BOOTH ACCESSORIES RENTAL



March 23rd – 25th 2018

Company: _____
 Street: _____
 City: _____ Prov: _____ Postal Code: _____
 Phone: _____ Fax: _____
 Contact Name: _____ Booth #: _____

Email address for receipt: _____

Visa MasterCard Cheque No AmEx

Card Holder Name: _____
 Card #: _____
 Expiry: M _____ Y _____
 Signature: _____

25% administration charge will apply to orders cancelled 2 weeks prior to show.
Orders must be pre-paid before closing at 5pm Monday prior to show date to receive pre-show price.

#	Description	Pre-show	On site	Qty	Total
1	Padded arm chair	14.00	17.50		
2	Director's chair - 30" high	17.00	21.25		
3	Metal & Wood bar stool with back	17.00	21.25		
4	Folding chairs	4.20	5.25		
5	Carpet : <input type="checkbox"/> Red <input type="checkbox"/> Blue <input type="checkbox"/> Grey <input type="checkbox"/> Green <input type="checkbox"/> 10' x 10' <input type="checkbox"/> 10' x 20' <input type="checkbox"/> 3/8" foam underpad (per sq. foot) (10' x 10' = \$50.00)	76.00 152.00 .55	101.00 190.00 .69		
6	Undraped tables: 30" wide x <input type="checkbox"/> 4' <input type="checkbox"/> 6' <input type="checkbox"/> 8' 18" wide x <input type="checkbox"/> 4' <input type="checkbox"/> 6' <input type="checkbox"/> 8'	19.00 19.00	24.00 24.00		
7	30" round pedestal table <input type="checkbox"/> 18" high <input type="checkbox"/> 30" high <input type="checkbox"/> 42" high	29.50	37.00		
7a	Black spandex table cover <input type="checkbox"/> 30" <input type="checkbox"/> 42" high	15.00	18.75		
8	Skirted tables (includes table, plastic cover, front & 2 sides skirted) <input type="checkbox"/> 4' <input type="checkbox"/> 6' <input type="checkbox"/> 8' long <input type="checkbox"/> 30" or <input type="checkbox"/> 18" wide <input type="checkbox"/> Royal Blue <input type="checkbox"/> Gold <input type="checkbox"/> Red <input type="checkbox"/> Teal <input type="checkbox"/> Navy Blue <input type="checkbox"/> White <input type="checkbox"/> Black <input type="checkbox"/> Burgundy	44.00	55.00		
9	***To skirt 4 sides or change table size ***	16.50	21.00		
10	Leg extenders (elevates table height to 42") <input type="checkbox"/> Royal Blue <input type="checkbox"/> White <input type="checkbox"/> Black skirting only	13.25	15.75		
13	Easel	18.00	22.50		
14	Sign stand – 22" x 28"	18.00	22.50		
15	Coat tree	11.00	13.75		
16	Coat rack with hangers	17.00	21.25		
17	Waste baskets	8.00	10.00		
18	Plants 2' live	22.00	27.50		
19	Drapery: <input type="checkbox"/> Royal Blue <input type="checkbox"/> Gold <input type="checkbox"/> Red <input type="checkbox"/> Teal <input type="checkbox"/> Green <input type="checkbox"/> Navy Blue <input type="checkbox"/> White <input type="checkbox"/> Black <input type="checkbox"/> Burgundy 8' high back (per linear ft) 3' high sides (per linear ft)	5.80 3.60	7.25 4.50		DRAPERY PROVIDED

Authorizing signature x _____

Subtotal:	_____
HST 13%:	_____
ADD \$7.50 FOR U.S. CHEQUES:	_____
Total:	_____

Complete and return to Hahn Rentals at address above.
All rates above are for the duration of show.
All claims/discrepancies must be settled prior to show closing.
REFUNDS will not be given on any orders changed or cancelled on site.
All materials remain the property of Hahn Rentals and will be removed upon show close.

H.S.T. R104250493
 2016 HAHN RENTALS



AUDIO/VIDEO EQUIPMENT RENTAL

KW HOME & GARDEN | MOHS

March 23rd – 25th 2018

95 Baffin Place, Waterloo, ON N2V 2C1
Phone: 519-746-8955
800-563-4246
Fax: 519-746-2188
Website: www.hahnrentals.com
Email: Info@hahnrentals.com

Visa MasterCard Cheque No AmEx

Card Holder Name: _____

Card #: _____

Expiry: M _____ Y _____

Signature: _____

Company: _____
Street: _____
City: _____ Prov: _____ Postal Code: _____
Phone: _____ Fax: _____
Contact Name: _____ Booth #: _____

Email address for receipt: _____

**25% administration charge will apply to orders cancelled 2 weeks prior to show.
Orders must be pre-paid before closing at 5pm Monday prior to show date to receive pre-show price.**

Description	1 Day Use	Extra Day	+25% On Site	Quantity	Total
TV / DVD COMBO		½ price x # of days			
27" Monitor w/ DVD	125.00				
32" Monitor w/ DVD	175.00				
NOTE THE ABOVE TV'S DO NOT PLAY BURNED DISCS					
COMPUTER MONITORS					
27" Flat-screen	100.00				
32" Flat-screen	150.00				
HDMI / VGA cables	8.00				
TELEVISIONS					
27" Flat-screen LCD	100.00				
32" Flat-screen LCD	150.00				
42" Flat-screen LCD	225.00				
50" Flat-screen LCD	300.00				
DVD Player	25.00				
Video Cart	20.00				
TV stand or wall mount	52.50	Flat rate	65.50		
Computer cables VGA (TV to computer)	7.50	Flat rate	9.38		
MISCELLANEOUS					
Microwave oven	47.50		62.50		
Bar Fridge	47.50		62.50		

Authorizing signature x _____

Subtotal: _____

HST 13%: _____

ADD \$7.50 FOR U.S. CHEQUES: _____

Total: _____

**Complete and return to Hahn Rentals at address above.
All rates above are for the duration of show.
All claims/discrepancies must be settled prior to show closing.
REFUNDS will not be given on any orders changed or cancelled on site.
All materials remain the property of Hahn Rentals and will be removed upon show close.**

H.S.T R104250493
2016 HAHN RENTALS

95 Baffin Place, Waterloo, ON N2V 2C1
 Phone: 519-746-8955
 800-563-4246
 Fax: 519-746-2188
 Website: www.hahnrentals.com
 Email: Info@hahnrentals.com

Visa MasterCard Cheque No AmEx

Card Holder Name: _____

Card #: _____

Expiry: M _____ Y _____

Signature: _____

Company: _____
 Street: _____
 City: _____ Prov: _____ Postal Code: _____
 Phone: _____ Fax: _____
 Contact Name: _____ Booth #: _____
 Email address for receipt: _____

25% administration charge will apply to orders cancelled 2 weeks prior to show.
Orders must be pre-paid before closing at 5pm Monday prior to show date to receive pre-show price.

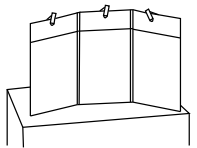
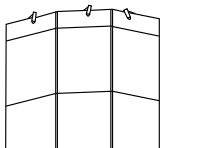
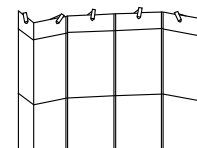
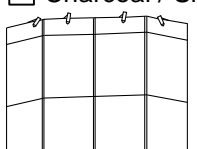
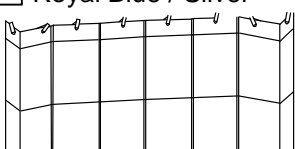
FS 28 Series		Pre-show	On-site
FS 28/35 Folding Stackable 3 panel display	<input type="checkbox"/> A -	170.00	215.00
FS 28/12 Folding Stackable header	<input type="checkbox"/> B -	236.00	295.00
<input type="checkbox"/> Charcoal / Silver <input type="checkbox"/> Royal Blue / Silver	<input type="checkbox"/> C -	430.00	537.00
 A	 B	 C	
FS 28/35 Folding Stackable 4 panel display	<input type="checkbox"/> E -	270.00	340.00
FS 28/17 Folding Stackable header	<input type="checkbox"/> F -	560.00	700.00
<input type="checkbox"/> Charcoal / Silver reversible <input type="checkbox"/> Royal Blue / Silver			
 E	 F		

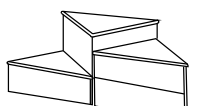
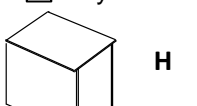
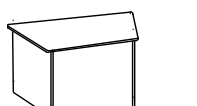
PEDESTAL BASES AND TOPS		Pre-show	On-site
G - 32.5" Triangular counter top – Silver (FS 28 series bases)	<input type="checkbox"/> G - 12" h	51.00	64.00
H - 32" x 20" Rectangle counter top – Black (FS 22 series bases black only)	<input type="checkbox"/> 24" h	58.00	73.00
I - 48" x 20" Trapezoidal counter top – Silver	<input type="checkbox"/> 35" h	63.00	79.00
Bases: for G & I <input type="checkbox"/> Silver <input type="checkbox"/> Royal Blue <input type="checkbox"/> Charcoal	<input type="checkbox"/> H - 35" h	63.00	79.00
 G	<input type="checkbox"/> I - 35" h	71.00	89.00
 H			
 I			

Authorizing signature x _____

Subtotal:	_____
HST 13%:	_____
ADD \$7.50 FOR U.S. CHEQUES:	_____
Total:	_____

Complete and return to Hahn Rentals at address above.
All rates above are for the duration of show.
All claims/discrepancies must be settled prior to show closing.
REFUNDS will not be given on any orders changed or cancelled on site.
All materials remain the property of Hahn Rentals and will be removed upon show close.

95 Baffin Place, Waterloo, ON N2V 2C1
 Phone: 519-746-8955
 800-563-4246
 Fax: 519-746-2188
 Website: www.hahnrentals.com
 Email: Info@hahnrentals.com

EXHIBIT SYSTEM RENTALS

March 23rd – 25th 2018

Company: _____
 Street: _____
 City: _____ Prov: _____ Postal Code: _____
 Phone: _____ Fax: _____
 Contact Name: _____ Booth #: _____
 Email address for receipt: _____

Visa MasterCard Cheque No AmEx

Card Holder Name: _____
 Card #: _____
 Expiry: M _____ Y _____
 Signature: _____

25% administration charge will apply to orders cancelled 2 weeks prior to show.
Orders must be pre-paid before closing at 5pm Monday prior to show date to receive pre-show price.

POLE / PANEL SERIES

HP style c/w 2 – 3' x 4' Panels & 1 – 16" x 4' Header per 4' section.
 VP style c/w 2 – 4' x 3' Panels per 3' section.

- Silver Charcoal Black
 Red Royal Blue

Custom design of any of these exhibits can be arranged.

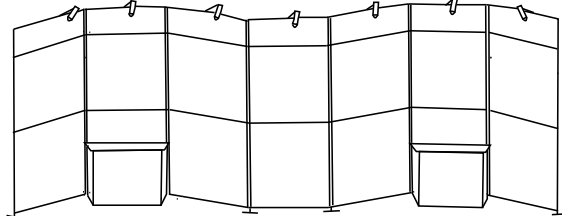

L

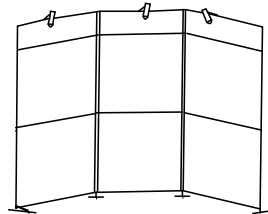

J

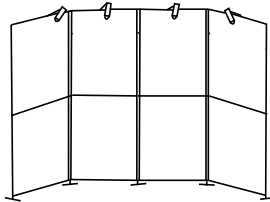

K

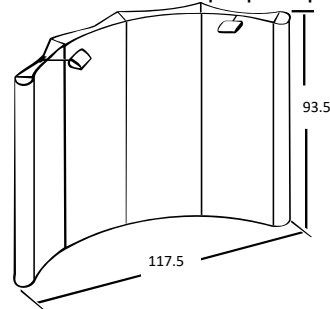

M

- J - HP Portable Exhibit System
 10' exhibit with 3 stem lights
 20' exhibit with 6 stem lights
- K - VP Portable Exhibit System
 10' exhibit with 4 stem lights
 20' exhibit with 8 stem lights
- L - Deluxe 20' Exhibit
 7 – 75w stem lights & 2 – 4' Trapezoidal counters
- M - 10' Hexa Black Pop-up Display

	Pre-show	On-site
<input type="checkbox"/> J - HP Portable Exhibit System		
<input type="checkbox"/> 10' exhibit with 3 stem lights	525.00	655.00
<input type="checkbox"/> 20' exhibit with 6 stem lights	1070.00	1335.00
<input type="checkbox"/> K - VP Portable Exhibit System		
<input type="checkbox"/> 10' exhibit with 4 stem lights	530.00	660.00
<input type="checkbox"/> 20' exhibit with 8 stem lights	1070.00	1335.00
<input type="checkbox"/> L - Deluxe 20' Exhibit		
7 – 75w stem lights & 2 – 4' Trapezoidal counters	1190.00	1485.00
<input type="checkbox"/> M - 10' Hexa Black Pop-up Display	525.00	655.00

Authorizing signature x _____

Subtotal:	_____
HST 13%:	_____
ADD \$7.50 FOR U.S. CHEQUES:	_____
Total:	_____

Complete and return to Hahn Rentals at address above.
All rates above are for the duration of show.
All claims/discrepancies must be settled prior to show closing.
REFUNDS will not be given on any orders changed or cancelled on site.
All materials remain the property of Hahn Rentals and will be removed upon show close.

H.S.T R104250493
 2016 HAHN RENTALS



PROUD SUPPLIER TO THE



KW HOME
& GARDEN | SHOW

SHOW SPECIALS

5000 Postcards from \$199.00

Pop Up Banners \$195.00

Pens from 51¢ each

FLYERS • BUSINESS CARDS • BANNERS

COFFEE MUGS • WATER BOTTLES

and much more!

WATERLOO

620 Davenport Road, Unit 16
519-725-4441
waterloo@minutemanpress.ca

KITCHENER

21 Third Avenue
T: 519-893-4755
print@minuteman.on.ca

design

print

copy

display